

Производственное предприятие «Виктория»

- Производство воздуховодов и систем вентиляции
- Клапаны противопожарные
- Клапаны дымоудаления
- Вентиляторы общепром, дымоудаления, крышные

г. Минск, Микрорайон Уручье, пр. Независимости, 199,
центральный корпус, помещение 1.

Тел. **8 (017) 399-83-88** E-mail: **5@v-klapan.by**

v-klapan.by

Картриджный пылесборник Donaldson Unicell



производственное предприятие

ВИКТОРИЯ

DATA SHEET

Unicell Dust Collectors

Series C10-90

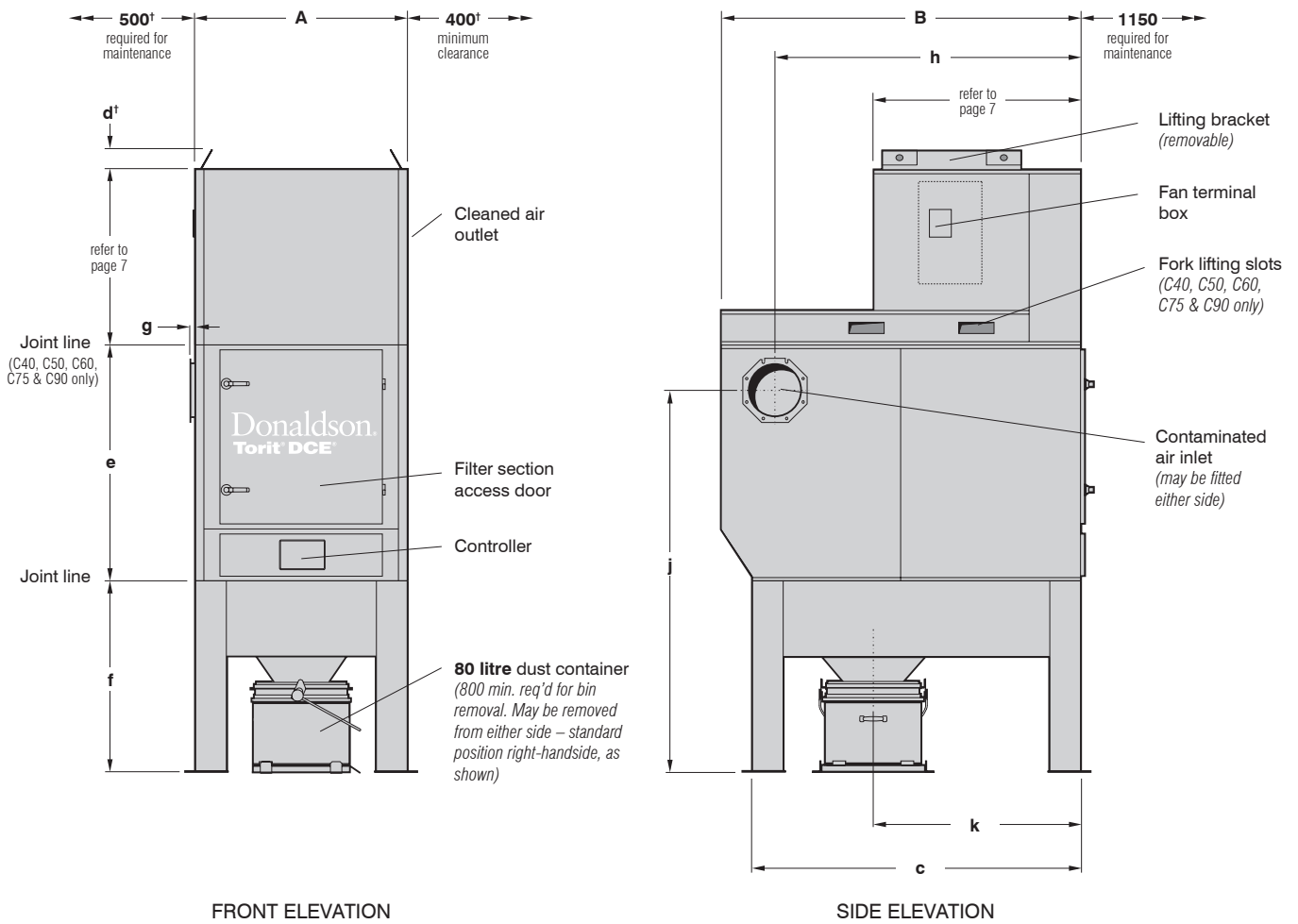

UNICELL DUST COLLECTOR WITH DUST CONTAINER
(C50-3 K10 illustrated)

SPECIFICATIONS

DIMENSIONS in mm

Type	Filtration area	A	B	c	d	e	f	g	h	j	k
C10-3	10 m ²	928	1380	1380	185	814	1040	12	1170	1667	785
C20-3	20 m ²	928	1380	1380	185	814	1040	12	1170	1667	785
C30-3	30 m ²	1280	1380	1380	185	814	1040	12	1170	1667	785
C40-3	40 m ²	1240	2100	1920	120	1475	1100	2	1780	2288	1210
C50-3	50 m ²	1240	2100	1920	120	1475	1100	2	1780	2288	1210
C60-3	60 m ²	1240	2100	1920	120	1475	1100	2	1780	2288	1210
C75-3	75 m ²	1240	2100	1920	120	2000	1100	2	1780	2765	1210
C90-3	90 m ²	1240	2100	1920	120	2000	1100	2	1780	2765	1210

Refer to page 9 for fan availability † Refer also to page 19 for clearances required for fan removal

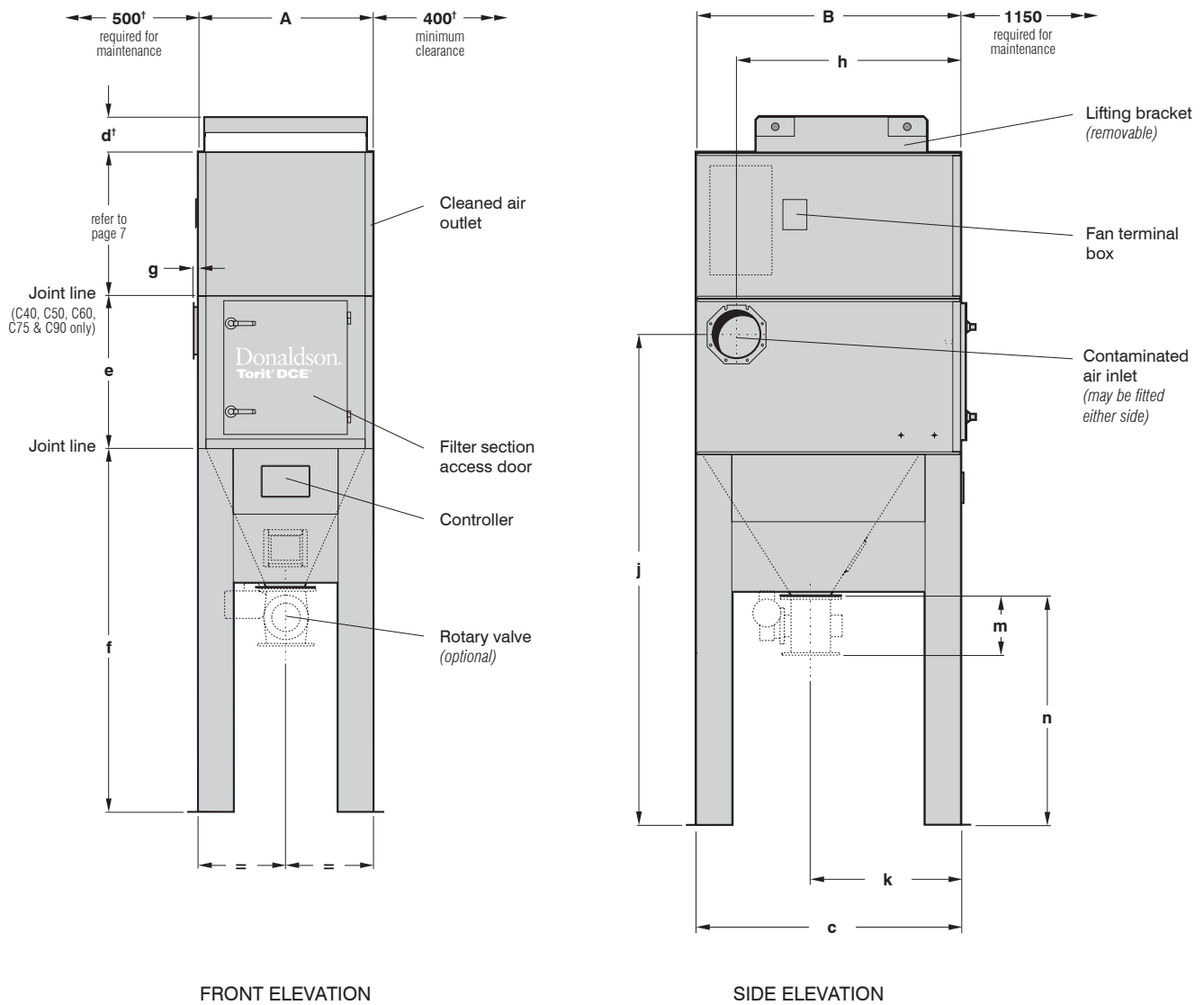

UNICELL DUST COLLECTOR WITH ROTARY VALVE
(C20 R K3 illustrated)

SPECIFICATIONS

DIMENSIONS in mm

Type	Filtration area	A	B	c	d	e	f	g	h	j	k	m	n
C10 R	10 m ²	928	1380	1380	185	814	1924	12	1170	2551	785	325	1200
C20 R	20 m ²	928	1380	1380	185	814	1924	12	1170	2551	785	325	1200
C30 R	30 m ²	1280	1380	1380	185	814	1924	12	1170	2551	785	325	1200
C40 R	40 m ²	1240	2100	1920*	120	1475	2182	2	1780	3370	1210	380	1206
C50 R	50 m ²	1240	2100	1920*	120	1475	2182	2	1780	3370	1210	380	1206
C60 R	60 m ²	1240	2100	1920*	120	1475	2182	2	1780	3370	1210	380	1206
C75 R	75 m ²	1240	2100	1920*	120	2000	2182	2	1780	3847	1210	380	1206
C90 R	90 m ²	1240	2100	1920*	120	2000	2182	2	1780	3847	1210	380	1206

Refer to page 9 for fan availability † Refer also to page 19 for clearances required for fan removal

*Measurement from front of collector

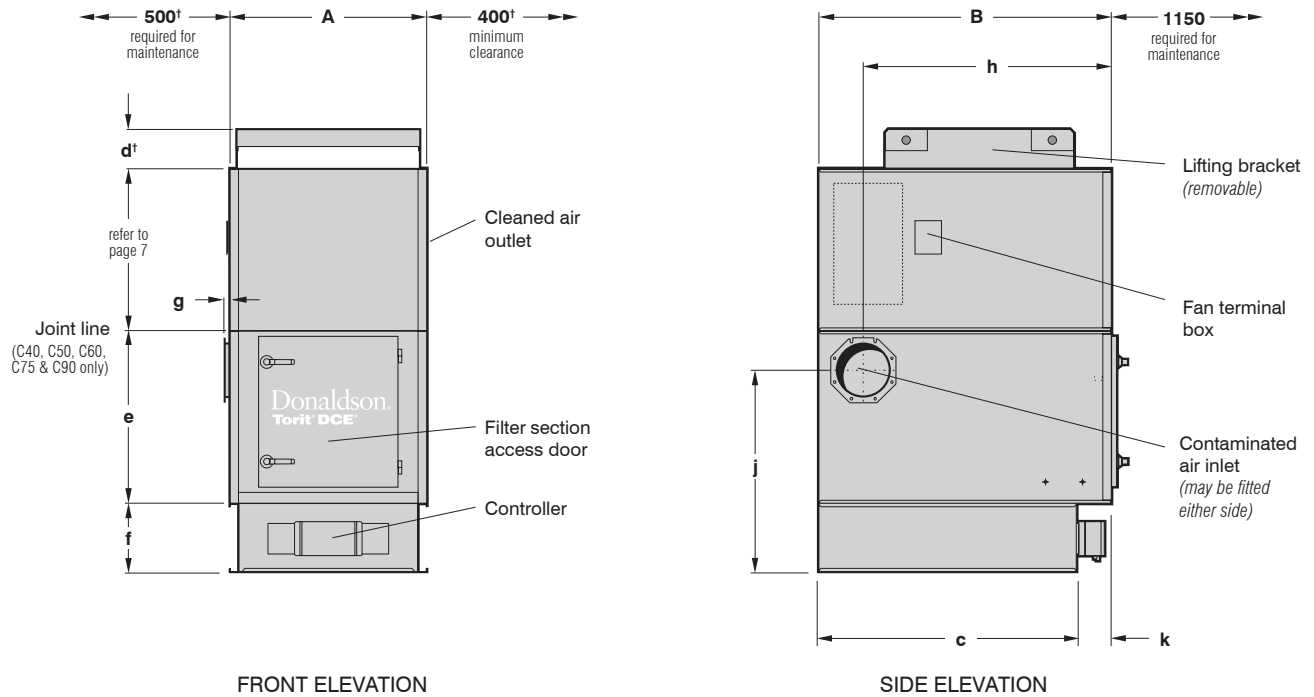

UNICELL HOPPER TYPE DUST COLLECTOR
(C20 H K3 illustrated)

SPECIFICATIONS

DIMENSIONS in mm

Type	Filtration area	A	B	c	d	e	f	g	h	j	k
C10 H	10 m ²	928	1380	1215	185	814	325	12	1170	952	165
C20 H	20 m ²	928	1380	1215	185	814	325	12	1170	952	165
C30 H	30 m ²	1280	1380	1215	185	814	325	12	1170	952	165
C40 H	40 m ²	1240	2100	1920*	120	1475	0	2	1780	1188	0
C50 H	50 m ²	1240	2100	1920*	120	1475	0	2	1780	1188	0
C60 H	60 m ²	1240	2100	1920*	120	1475	0	2	1780	1188	0
C75 H	75 m ²	1240	2100	1920*	120	2000	0	2	1780	1665	0
C90 H	90 m ²	1240	2100	1920*	120	2000	0	2	1780	1665	0

Refer to page 9 for fan availability † Refer also to page 19 for clearances required for fan removal
*Measurement from front of collector

DESIGN LIMITS (standard equipment)

Temperature range: -10° to +60°C

Pressure limits: Collectors with fan: as fan performance curves from shut-off to operating pressure
Collectors without fan: -500 mm W.G. (For positive pressures refer to Donaldson)

Dimension tolerances: ±3 mm on main dimensions; ±2 mm on detail dimensions

Equipment is available suitable for use in a potentially explosive atmosphere (Directive 94/9/EC) satisfying the requirements for group II category 2G or 2D and 3G or 3D T135°C

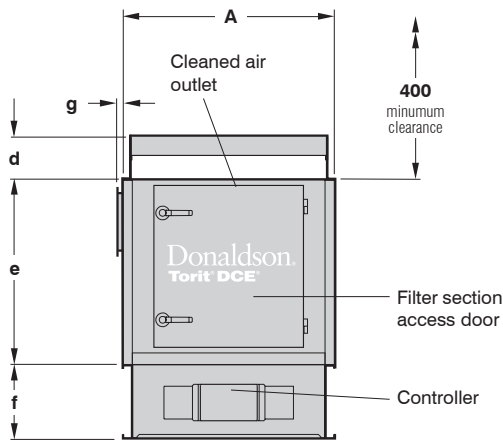

FRONT ELEVATION

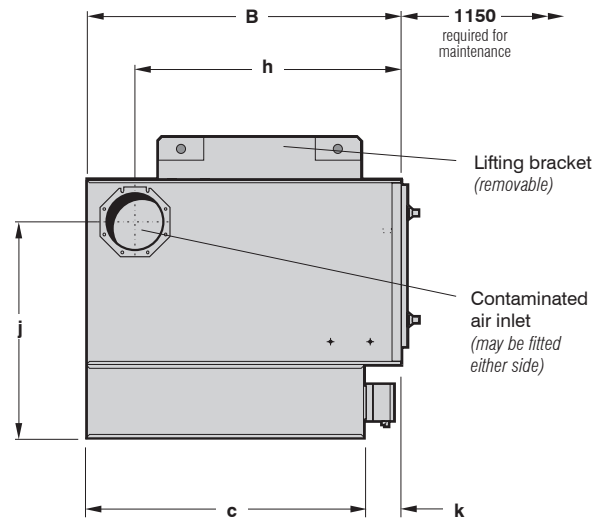

SIDE ELEVATION

UNICELL VENTING TYPE DUST COLLECTOR
(C20 V illustrated)

SPECIFICATIONS

DIMENSIONS in mm

Type	Filtration area	A	B	c	d	e	f	g	h	j	k
C10 V	10 m ²	928	1380	1215	185	814	325	12	1170	952	165
C20 V	20 m ²	928	1380	1215	185	814	325	12	1170	952	165
C30 V	30 m ²	1280	1380	1215	185	814	325	12	1170	952	165
C40 V	40 m ²	1240	2100	1920*	120	1675	0	2	1780	1188	0
C50 V	50 m ²	1240	2100	1920*	120	1675	0	2	1780	1188	0
C60 V	60 m ²	1240	2100	1920*	120	1675	0	2	1780	1188	0
C75 V	75 m ²	1240	2100	1920*	120	2200	0	2	1780	1665	0
C90 V	90 m ²	1240	2100	1920*	120	2200	0	2	1780	1665	0

*Measurement from front of collector

ELECTRICAL REQUIREMENTS

- C10:** 2-way controller
- C20 and C40:** 4-way controller
- C50 and C75:** 5-way controller
- C30, C60 and C90:** 6-way controller
- Controller voltage input:** **AC version:** 105-120V, 200-240V ±10%
DC version: 24V
- Fan motor:** To suit local voltage

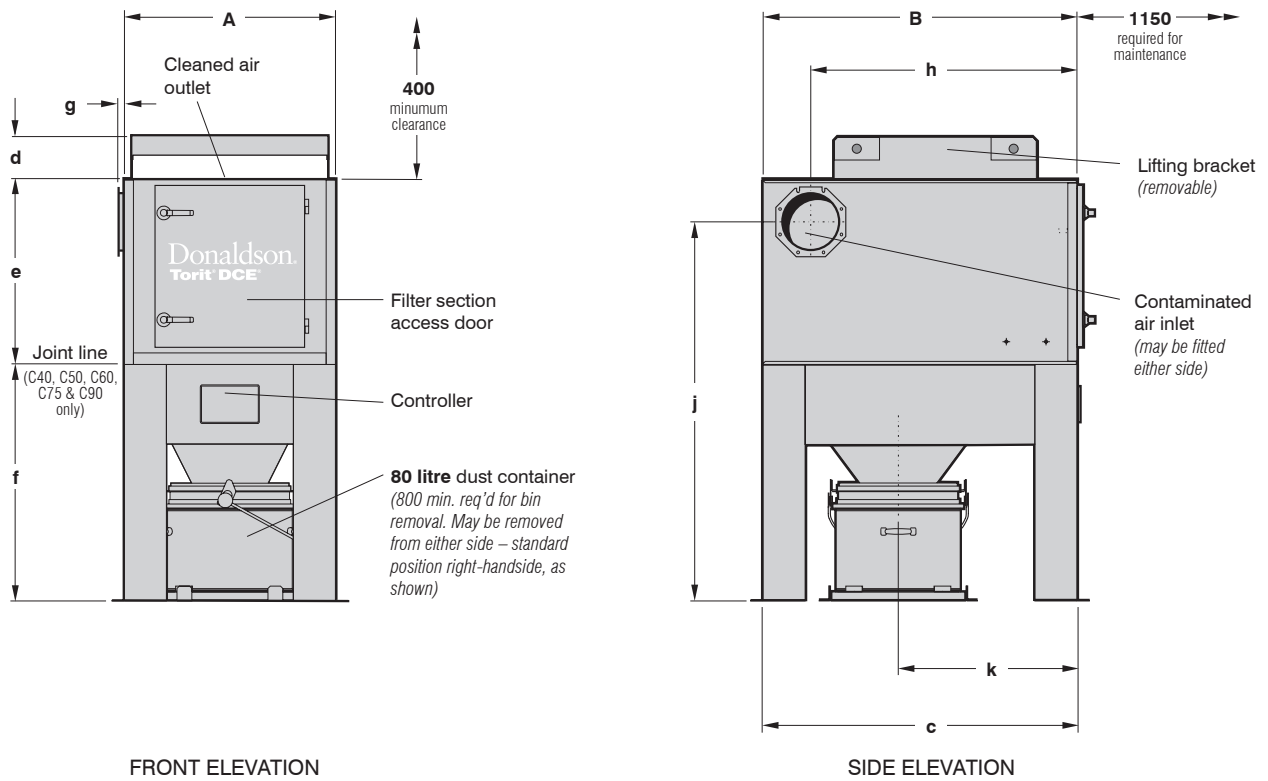

UNICELL VENTING TYPE DUST COLLECTOR WITH DUST CONTAINER
(C20-3 V illustrated)

SPECIFICATIONS

DIMENSIONS in mm

Type	Filtration area	A	B	c	d	e	f	g	h	j	k
C10-3 V	10 m ²	928	1380	1380	814	814	1040	12	1170	1667	785
C20-3 V	20 m ²	928	1380	1380	814	814	1040	12	1170	1667	785
C30-3 V	30 m ²	1280	1380	1380	814	814	1040	12	1170	1667	785
C40-3 V	40 m ²	1240	2100	1920*	1675	1675	1100	2	1780	2288	1210
C50-3 V	50 m ²	1240	2100	1920*	1675	1675	1100	2	1780	2288	1210
C60-3 V	60 m ²	1240	2100	1920*	1675	1675	1100	2	1780	2288	1210
C75-3 V	75 m ²	1240	2100	1920*	1675	2200	1100	2	1780	2765	1210
C90-3 V	90 m ²	1240	2100	1920*	2200	2200	1100	2	1780	2765	1210

*Measurement from front of collector

DUST CONTAINER

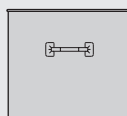

80 litre
(3 cu.ft.)

Size
80 litre

Approx. net weight
6 kg

A reasonable total load for removal by hand would be 25 kg

Typical dust densities

Dust	Density with 50% voidage
Sander	0.13 kg/litre
Graphite	0.80 kg/litre
Sand	1.33 kg/litre
Iron	3.58 kg/litre
Steel	3.72 kg/litre

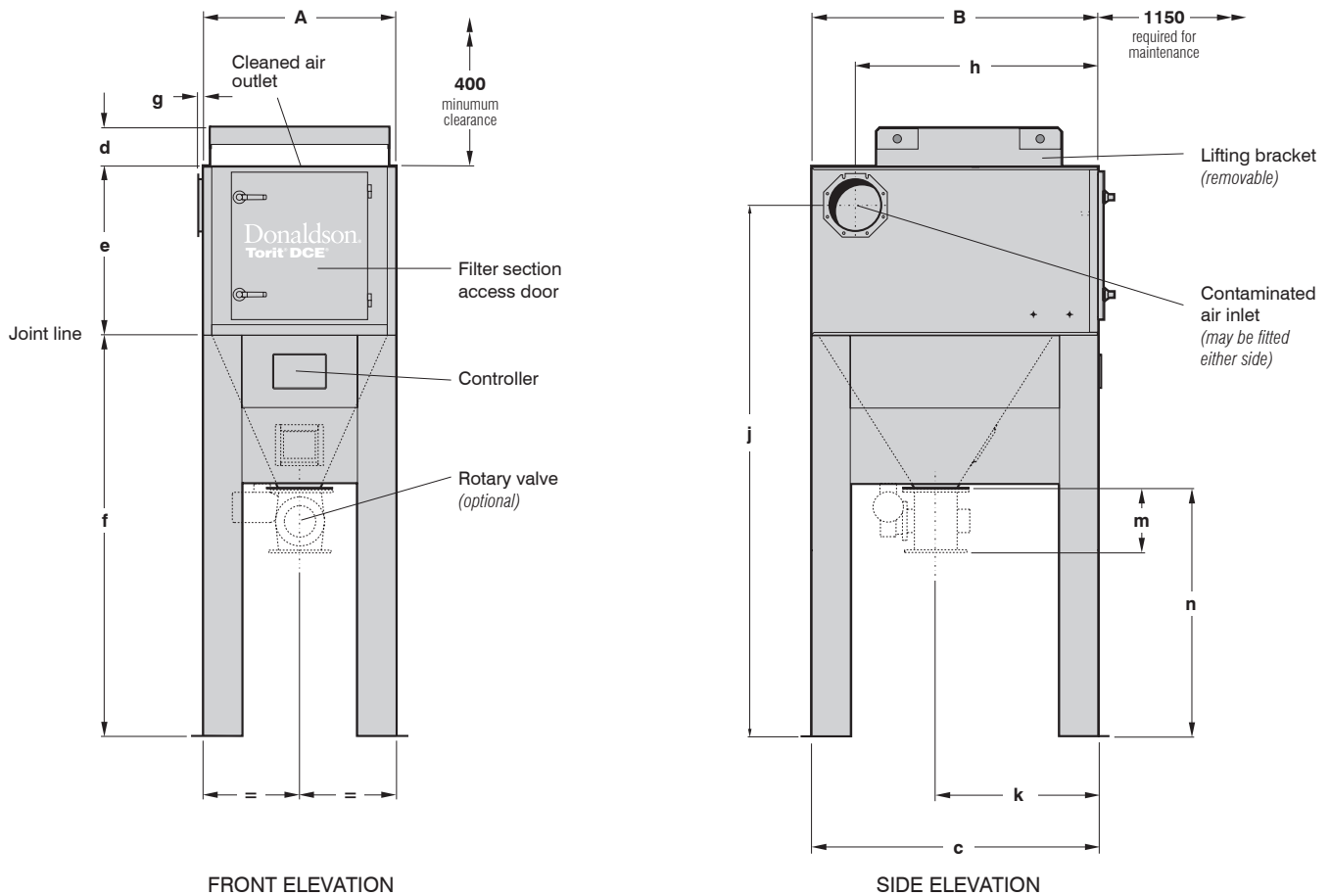

UNICELL VENTING TYPE DUST COLLECTOR WITH ROTARY VALVE
(C20 VR illustrated)

SPECIFICATIONS

DIMENSIONS in mm

Type	Filtration area	A	B	c	d	e	f	g	h	j	k	m	n
C10 VR	10 m ²	928	1380	1380	185	814	1924	12	1170	2551	785	325	1200
C20 VR	20 m ²	928	1380	1380	185	814	1924	12	1170	2551	785	325	1200
C30 VR	30 m ²	1280	1380	1380	185	814	1924	12	1170	2551	785	325	1200
C40 VR	40 m ²	1240	2100	1920*	120	1475	2182	2	1780	3370	1210	380	1206
C50 VR	50 m ²	1240	2100	1920*	120	1475	2182	2	1780	3370	1210	380	1206
C60 VR	60 m ²	1240	2100	1920*	120	1475	2182	2	1780	3370	1210	380	1206
C75 VR	75 m ²	1240	2100	1920*	120	2000	2182	2	1780	3847	1210	380	1206
C90 VR	90 m ²	1240	2100	1920*	120	2000	2182	2	1780	3847	1210	380	1206

*Measurement from front of collector

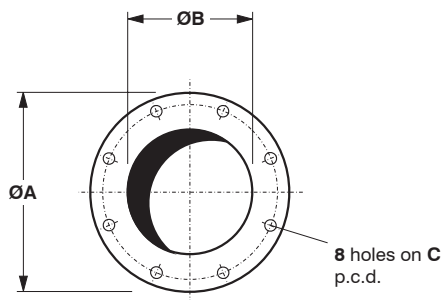

DIMENSIONS in mm

Type	A	B	C
C10, C20 and C30	340	200	280
C40, C50, C60, C75 and C90	395	250	350

ROTARY VALVE OUTLET FLANGE DETAILS
(for rotary valve supplied by Donaldson)

All holes Ø14mm for M12 bolts. Flange is 10mm thick

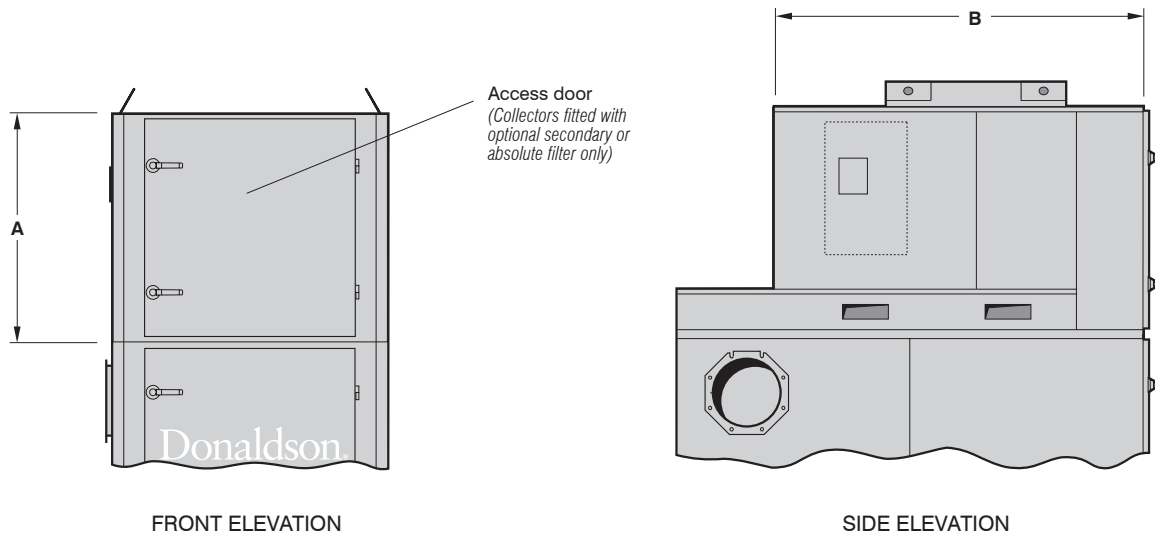

UNICELL DUST COLLECTOR INCLUDING DETAILS FOR OPTIONAL SECONDARY OR ABSOLUTE FILTER

(C50 K10 with secondary filter illustrated)

All other dimensions are as indicated on pages 1 to 3, depending on the type of collector

SPECIFICATIONS		DIMENSIONS in mm	
Type	Fan type (refer to page 9 for availability)	A	B
C10, C20 and C30			
Unit only and unit with secondary or absolute filter	K3, K5, K7, G8, K10 or K11	764	1380
C40, C50, C60, C75 and C90			
Unit only	K10 or K11	1025	1210
	K15, K18 or K21	1225	1620
Unit with secondary filter or absolute filter	K10* or K11*	1025	1690
	K15, K18 or K21	1225	2100

*Secondary or absolute filters are not available for C60 collectors fitted with K10 type fan, or for C60, C75 and C90 collectors fitted with K11 type fan

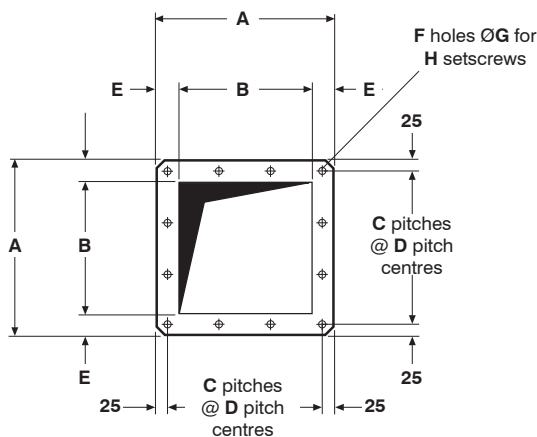

Type	A	B	C	D	E	F	G	H
C10, C20 and C30	320 mm	200 mm	3	90 mm	60 mm	12	12 mm	M10
C40, C50, C60, C75 and C90	352 mm	252 mm	2	151 mm	50 mm	8	14 mm	M12

HOPPER OUTLET FLANGE DETAILS FOR ROTARY VALVE

(C10-30 illustrated)

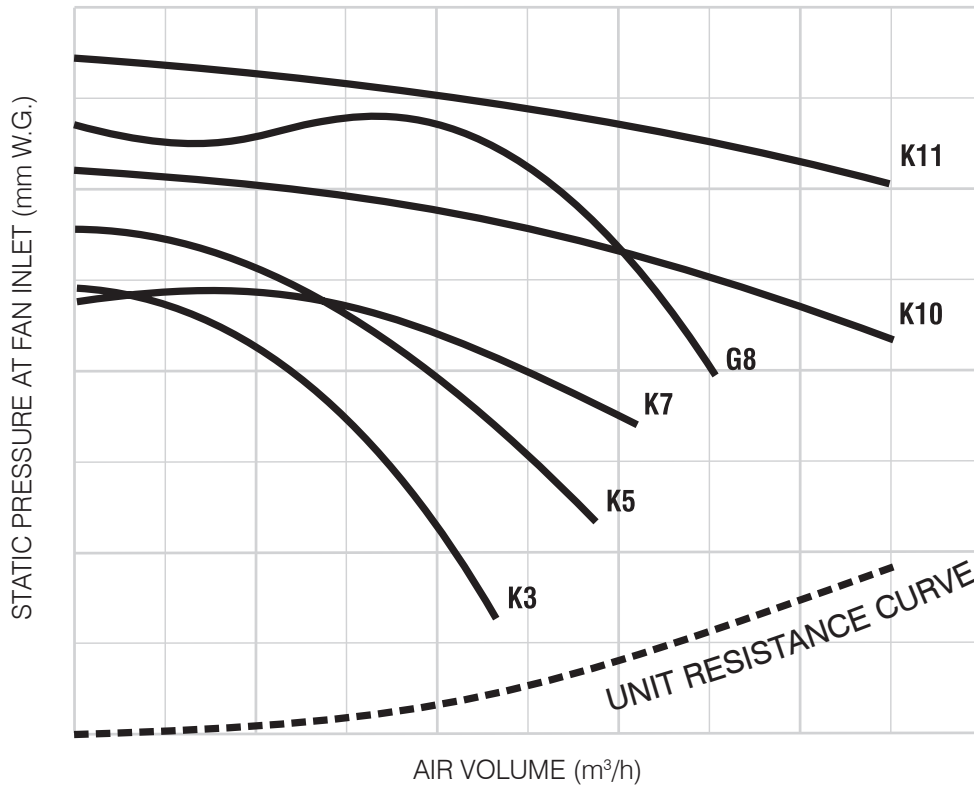

C10, C20 and C30 dust collectors

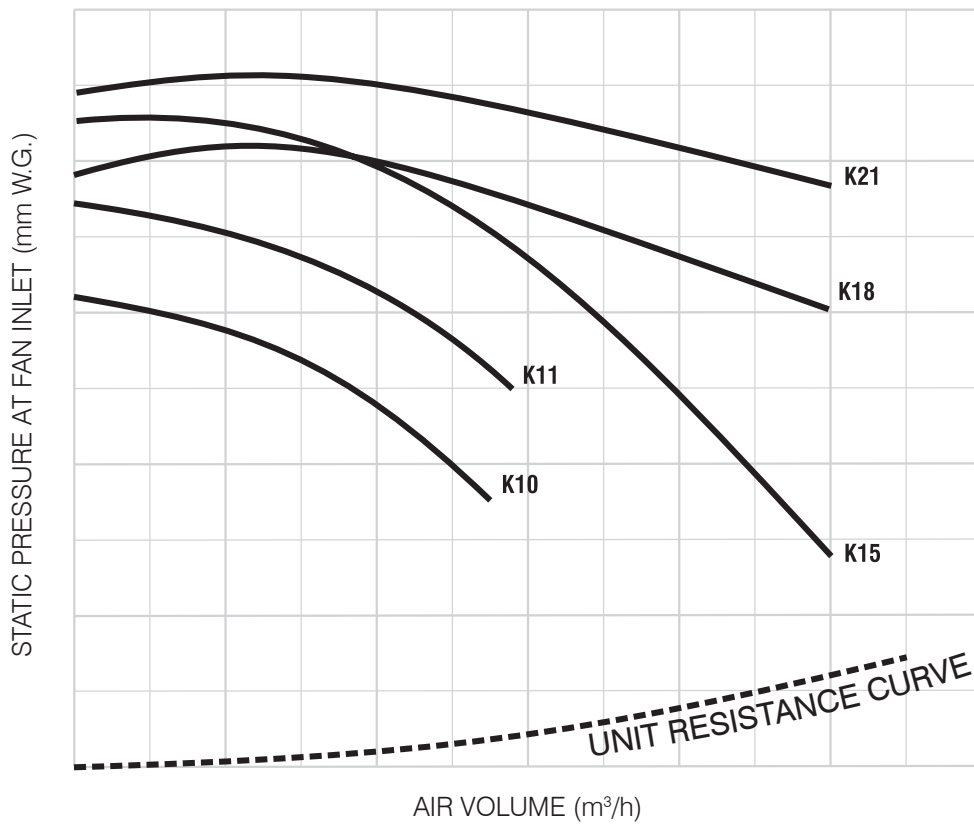

C40, C50, C60, C75 and C90 dust collectors

FAN PERFORMANCE CURVES

FAN SELECTION

These curves indicate static pressure available at fan inlet for a given volume when fitted inside a Unicell dust collector.

To select the most suitable fan for a given application:

- 1 Determine the air volume, in m³/h, needed to entrain the dust.
- 2 Read off the unit resistance, in mm W.G., at air volume required.
- 3 Assess pressure drop over filter bags prior to cleaning, usually 50 to 125 mm W.G.
- 4 Estimate pressure drop through connected system – i.e. between point of entrainment and collector inlet.
- 5 The sum of **2**, **3** and **4** = W.G. required.
- 6 Consult graph for fan performances available.

FAN AVAILABILITY

Type	Fan type: Motor rating:	K3	K5	K7	G8	K10	K11	K15	K18	K21
		1.5 kW	2.2 kW	3.0 kW	5.5 kW	5.5 kW	7.5 kW	11.0 kW	15.0 kW	18.5 kW
C10 and C20		●	●	●	●	-	-	-	-	-
C30		●	●	●	●	●	●	-	-	-
C40		-	-	-	-	●	●	●	-	-
C50		-	-	-	-	●	●	●	●	-
C60		-	-	-	-	○	○	●	●	-
C75 and C90		-	-	-	-	-	○	●	●	●

An acoustic diffuser is fitted as standard ○ Not available with secondary or absolute filter

NOISE LEVELS

Machinery noise levels are an important consideration in the design and selection of new equipment. Several EC Directives and National Laws/Regulations adopting these directives make reference to airborne noise emissions. Actions that employers are required to comply with if employees are subjected to a daily personal noise exposure Lep,d of 85 dB(A) or more are also specified.

All Unicell dust collectors, when fitted with an acoustic diffuser, secondary filter or absolute filter, operating an 8 hour shift, are below this action limit.

WEIGHTED SOUND PRESSURE LEVELS

All readings were taken in normal industrial areas, i.e. semi-reverberant surroundings, with local equipment silent. Measurements were taken at maximum air flow conditions at 1.0 metre radius from the equipment housing and 1.6 metres above base level, using a precision sound level meter and octave filter.

Collectors tested were of standard configuration i.e. with acoustic diffuser

K3	K5	K7	G8	K10	K11	K15	K18	K21
66 dB(A)	72 dB(A)	73 dB(A)	75 dB(A)	74 dB(A)	76 dB(A)*	79 dB(A)	81 dB(A)	82 dB(A)

Noise levels of installed equipment may vary due to site conditions *Measured data

APPROXIMATE NET WEIGHTS

Unicell dust collector with dust container

Type	Fan type	Unit only	Unit with secondary filter	Unit with absolute filter
C10-3	K3	548 kg	577 kg	579 kg
	K5	563 kg	592 kg	594 kg
	K7	588 kg	617 kg	619 kg
	G8	603 kg	632 kg	634 kg
C20-3	K3	559 kg	588 kg	590 kg
	K5	574 kg	603 kg	605 kg
	K7	599 kg	628 kg	630 kg
	G8	614 kg	643 kg	645 kg
C30-3	K3	653 kg	689 kg	700 kg
	K5	668 kg	704 kg	715 kg
	K7	693 kg	729 kg	740 kg
	G8	708 kg	744 kg	755 kg
	K10	723 kg	759 kg	770 kg
	K11	788 kg	824 kg	835 kg
C40-3	K10	1124 kg	1198 kg	1247 kg
	K11	1184 kg	1258 kg	1307 kg
	K15	1279 kg	1363 kg	1413 kg
C50-3	K10	1134 kg	1208 kg	1257 kg
	K11	1194 kg	1268 kg	1317 kg
	K15	1289 kg	1373 kg	1423 kg
	K18	1314 kg	1398 kg	1448 kg
C60-3	K10	1144 kg	–	–
	K11	1204 kg	–	–
	K15	1299 kg	1395 kg	1431 kg
	K18	1324 kg	1420 kg	1456 kg
C75-3	K11	1389 kg	–	–
	K15	1484 kg	1580 kg	1616 kg
	K18	1509 kg	1605 kg	1641 kg
	K21	1614 kg	1710 kg	1746 kg
C90-3	K11	1404 kg	–	–
	K15	1499 kg	1595 kg	1631 kg
	K18	1524 kg	1620 kg	1656 kg
	K21	1629 kg	1725 kg	1761 kg

Unicell dust collector with rotary valve

Type	Fan type	Unit only	Unit with secondary filter	Unit with absolute filter
C10 R	K3	617 kg	646 kg	648 kg
	K5	606 kg	635 kg	637 kg
	K7	631 kg	660 kg	662 kg
	G8	646 kg	675 kg	677 kg
C20 R	K3	602 kg	631 kg	633 kg
	K5	617 kg	646 kg	648 kg
	K7	642 kg	671 kg	673 kg
	G8	657 kg	686 kg	688 kg
C30 R	K3	703 kg	739 kg	750 kg
	K5	718 kg	754 kg	765 kg
	K7	743 kg	779 kg	790 kg
	G8	758 kg	794 kg	805 kg
	K10	773 kg	809 kg	820 kg
	K11	838 kg	874 kg	885 kg
C40 R	K10	1015 kg	1089 kg	1138 kg
	K11	1075 kg	1149 kg	1198 kg
	K15	1170 kg	1254 kg	1304 kg
C50 R	K10	1025 kg	1099 kg	1148 kg
	K11	1085 kg	1159 kg	1208 kg
	K15	1180 kg	1264 kg	1314 kg
	K18	1205 kg	1289 kg	1339 kg
C60 R	K10	1035 kg	–	–
	K11	1095 kg	–	–
	K15	1190 kg	1286 kg	1322 kg
	K18	1215 kg	1311 kg	1347 kg
C75 R	K11	1280 kg	–	–
	K15	1375 kg	1689 kg	1725 kg
	K18	1400 kg	1714 kg	1750 kg
	K21	1505 kg	1819 kg	1855 kg
C90 R	K11	1295 kg	–	–
	K15	1390 kg	1704 kg	1740 kg
	K18	1415 kg	1729 kg	1765 kg
	K21	520 kg	1834 kg	1870 kg

All weights shown indicate heaviest configuration

APPROXIMATE NET WEIGHTS

Unicell hopper type dust collector

Type	Fan type	Unit only	Unit with secondary filter	Unit with absolute filter
C10-3	K3	548 kg	577 kg	579 kg
	K5	563 kg	592 kg	594 kg
	K7	588 kg	617 kg	619 kg
	G8	603 kg	632 kg	634 kg
C20-3	K3	559 kg	588 kg	590 kg
	K5	574 kg	603 kg	605 kg
	K7	599 kg	628 kg	630 kg
	G8	614 kg	643 kg	645 kg
C30-3	K3	653 kg	689 kg	700 kg
	K5	668 kg	704 kg	715 kg
	K7	693 kg	729 kg	740 kg
	G8	708 kg	744 kg	755 kg
	K10	723 kg	759 kg	770 kg
C40-3	K11	788 kg	824 kg	835 kg
	K10	1124 kg	1198 kg	1247 kg
	K11	1184 kg	1258 kg	1307 kg
C50-3	K15	1279 kg	1363 kg	1413 kg
	K10	1134 kg	1208 kg	1257 kg
	K11	1194 kg	1268 kg	1317 kg
	K15	1289 kg	1373 kg	1423 kg
C60-3	K18	1314 kg	1398 kg	1448 kg
	K10	1144 kg	-	-
	K11	1204 kg	-	-
	K15	1299 kg	1395 kg	1431 kg
C75-3	K18	1324 kg	1420 kg	1456 kg
	K11	1389 kg	-	-
	K15	1484 kg	1580 kg	1616 kg
	K18	1509 kg	1605 kg	1641 kg
C90-3	K21	1614 kg	1710 kg	1746 kg
	K11	1404 kg	-	-
	K15	1499 kg	1595 kg	1631 kg
	K18	1524 kg	1620 kg	1656 kg
	K21	1629 kg	1725 kg	1761 kg

Unicell venting type dust collector

Type	Fan type	Unit only	Unit with secondary filter	Unit with absolute filter
C10 V	-	208 kg	-	-
C20 V	-	219 kg	-	-
C30 V	-	281 kg	-	-
C40 V	-	530 kg	-	-
C50 V	-	540 kg	-	-
C60 V	-	550 kg	-	-
C75 V	-	735 kg	-	-
C90 V	-	750 kg	-	-

Unicell venting type dust collector with dust container

Type	Fan type	Unit only	Unit with secondary filter	Unit with absolute filter
C10-3 V	-	338 kg	-	-
C20-3 V	-	349 kg	-	-
C30-3 V	-	421 kg	-	-
C40-3 V	-	849 kg	-	-
C50-3 V	-	859 kg	-	-
C60-3 V	-	869 kg	-	-
C75-3 V	-	1054 kg	-	-
C90-3 V	-	1069 kg	-	-

Unicell venting type dust collector with rotary valve

Type	Fan type	Unit only	Unit with secondary filter	Unit with absolute filter
C10 VR	-	381 kg	-	-
C20 VR	-	392 kg	-	-
C30 VR	-	471 kg	-	-
C40 VR	-	740 kg	-	-
C50 VR	-	750 kg	-	-
C60 VR	-	760 kg	-	-
C75 VR	-	945 kg	-	-
C90 VR	-	960 kg	-	-

All weights shown indicate heaviest configuration

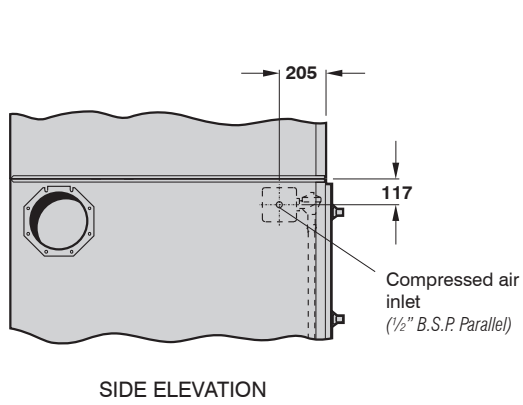

All C10-30 collectors

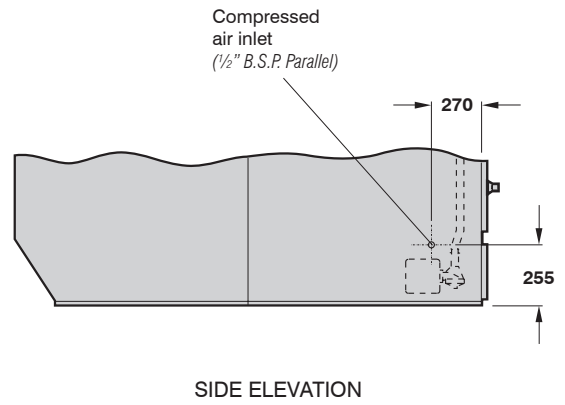

C40-90 hopper and venting type collectors and all C40-90 collectors supplied with PT controller or optional compressed air assembly

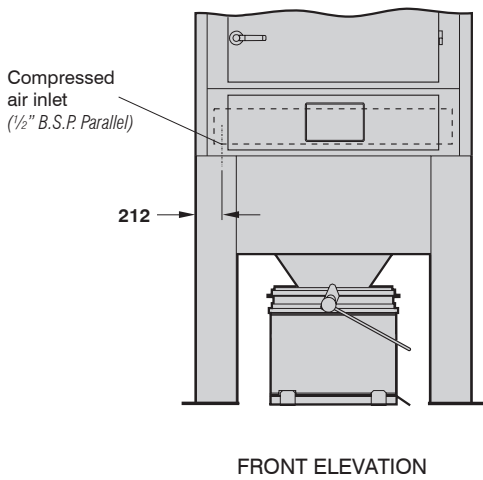

FRONT ELEVATION

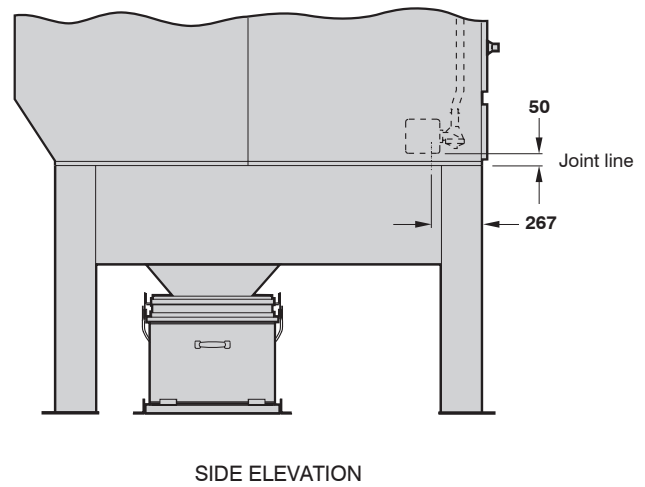

SIDE ELEVATION

C40-90 standard and venting type collectors with dust container or rotary valve*

*For C40-90 collectors supplied with PT controller or optional compressed air assembly, refer to illustration at top-right of page

POSITION OF COMPRESSED AIR CONNECTION TO COLLECTOR

COMPRESSED AIR REQUIREMENTS

Type	Working compressed air pressure ^a	Atmospheric air volume – F.A.D. ^b at 12 sec. intervals ^c	Pulse duration
C10	3.7 bar 55 psig	7.3 m ³ /h 4.3 cfm	100 millisec.
C20	3.7 bar 55 psig	7.3 m ³ /h 4.3 cfm	100 millisec.
C30	3.7 bar 55 psig	9.6 m ³ /h 5.7 cfm	100 millisec.
C40	4.5 bar 65 psig	13.7 m ³ /h 8.1 cfm	100 millisec.
C50	4.5 bar 65 psig	13.7 m ³ /h 8.1 cfm	100 millisec.
C60	4.5 bar 65 psig	13.7 m ³ /h 8.1 cfm	100 millisec.
C75	5.2 bar 75 psig	15.6 m ³ /h 9.2 cfm	100 millisec.
C90	5.2 bar 75 psig	15.6 m ³ /h 9.2 cfm	100 millisec.

^a Normal operating pressure ^b Recommended atmospheric air volume of clean, dry compressed air

^c Recommended initial settings; these may be varied with experience

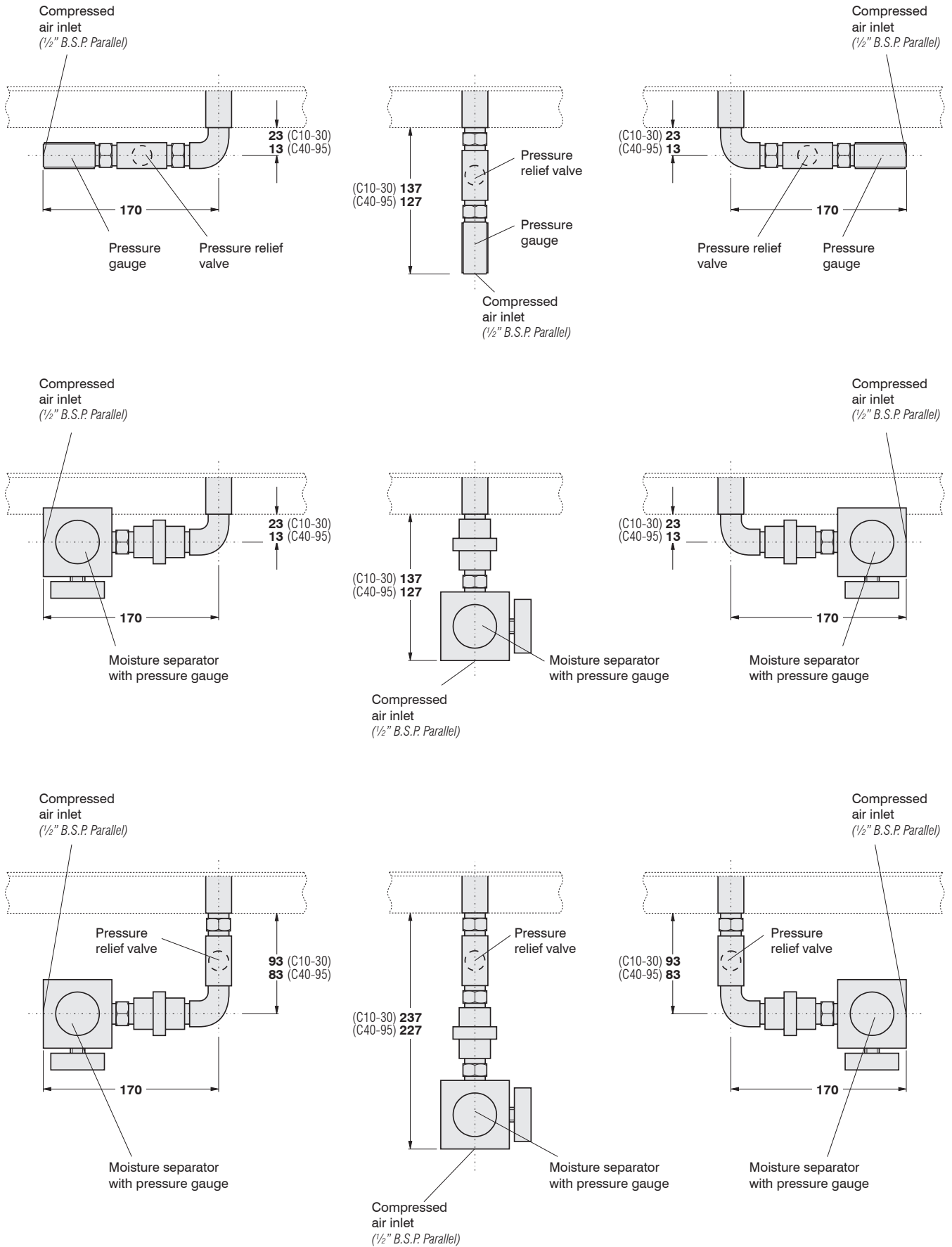

OPTIONAL COMPRESSED AIR ASSEMBLY DETAILS SHOWING ALTERNATIVE ARRANGEMENTS

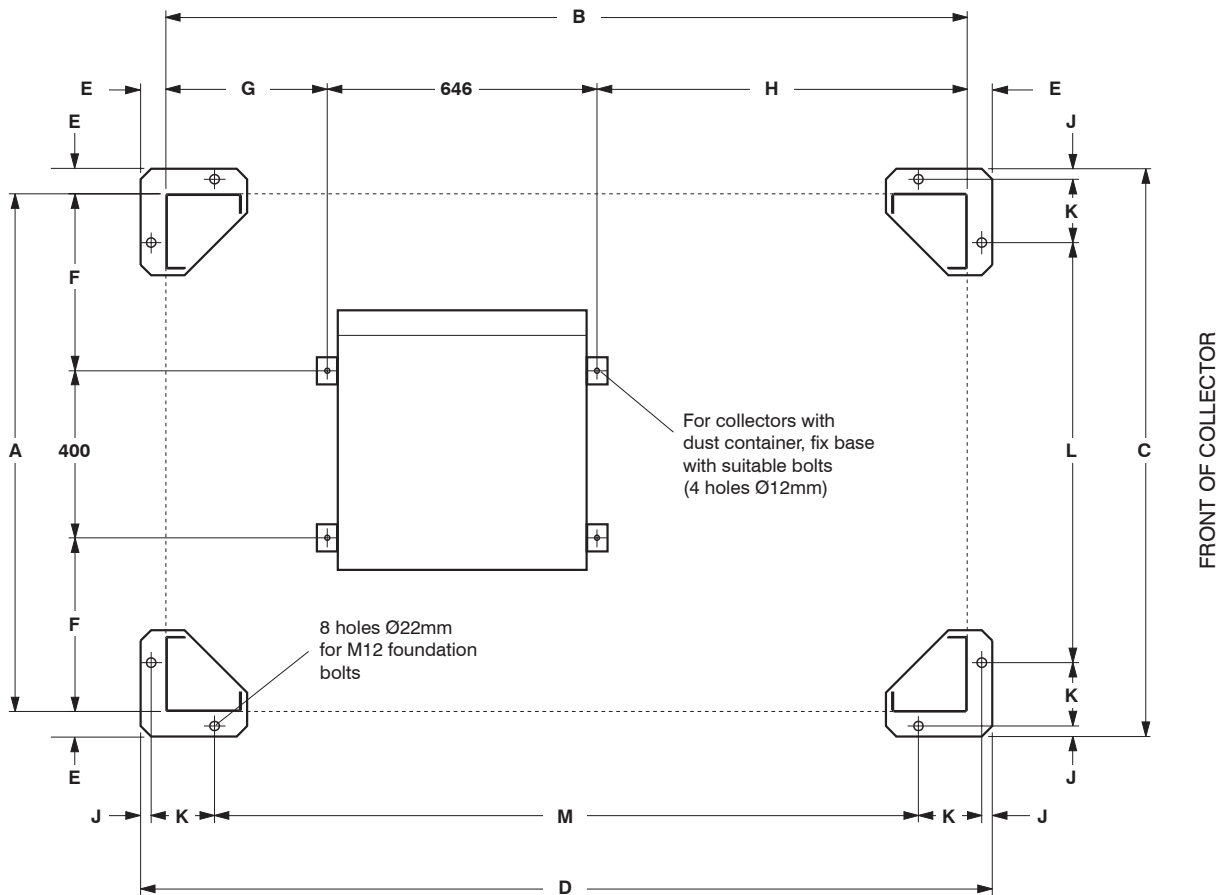

FOUNDATION DETAILS FOR STANDARD AND VENTING TYPE COLLECTORS WITH DUST CONTAINER OR ROTARY VALVE (C40-90 illustrated)

DIMENSIONS in mm

Type	A	B	C	D	E	F	G	H	J	K	L	M
C10	928	1380	1038	1490	55	264	272	462	20	157	684	1136
C20	928	1380	1038	1490	55	264	272	462	20	157	684	1136
C30	1280	1380	1390	1490	55	440	272	462	20	157	1036	1136
C40	1240	1920*	1360	2040	60	420	387	887	25	152	1006	1686
C50	1240	1920*	1360	2040	60	420	387	887	25	152	1006	1686
C60	1240	1920*	1360	2040	60	420	387	887	25	152	1006	1686
C75	1240	1920*	1360	2040	60	420	387	887	25	152	1006	1686
C90	1240	1920*	1360	2040	60	420	387	887	25	152	1006	1686

*Measurement from front of collector

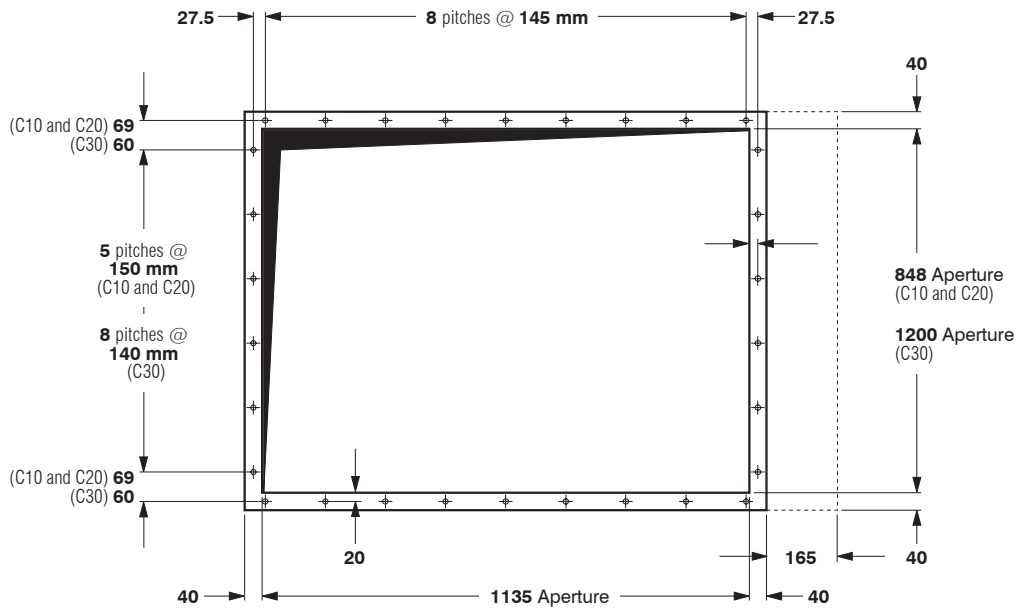

FRONT OF COLLECTOR

C10, C20 and C30
(C10 and C20 illustrated)

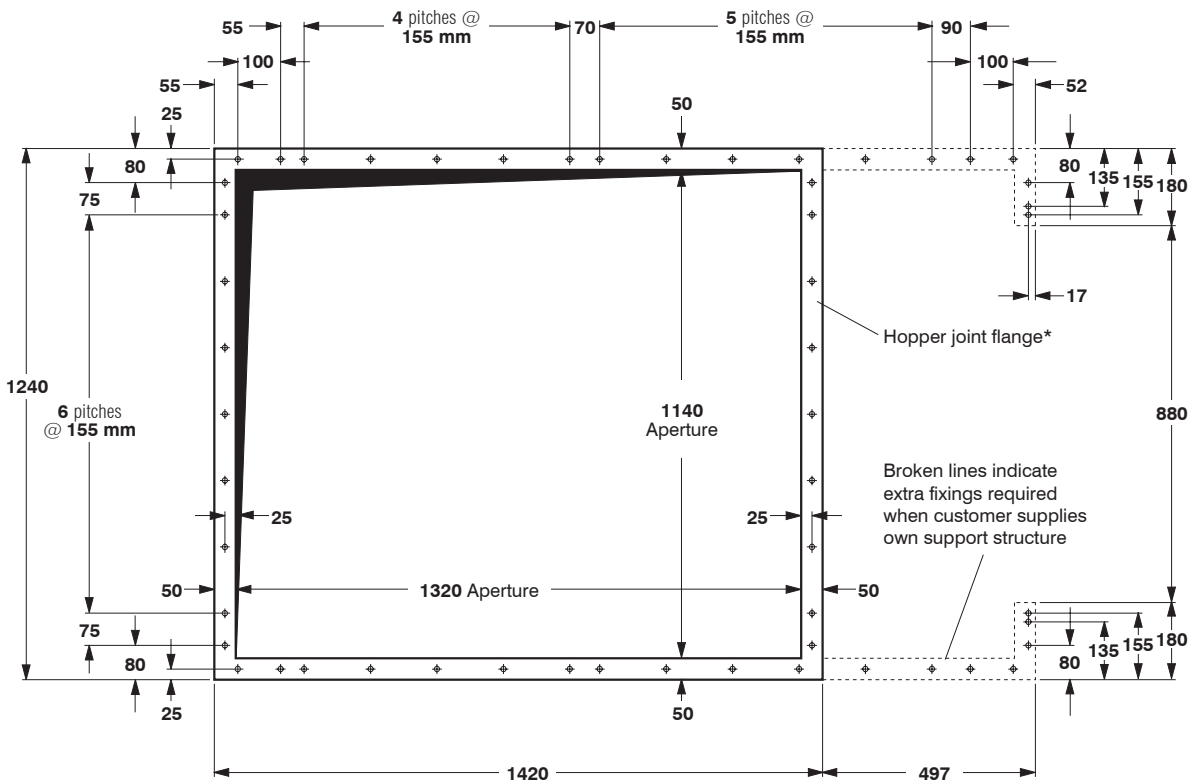

FRONT OF COLLECTOR

C40, C50, C60, C75 and C90

*NOTE: Access will be required to the underside of the hopper joint flange, e.g. via customer upstand

APERTURE AND MOUNTING FLANGE DETAILS FOR HOPPER AND VENTING TYPE COLLECTORS
All holes Ø12mm for M10 set screws

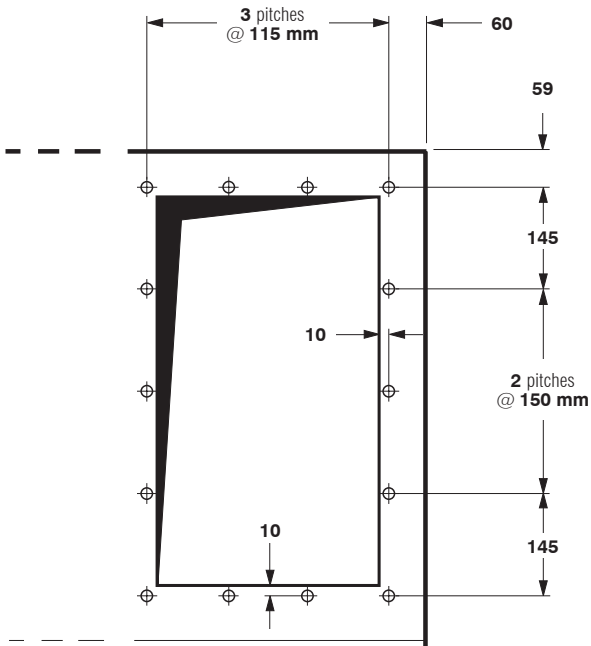

C10, C20 and C30

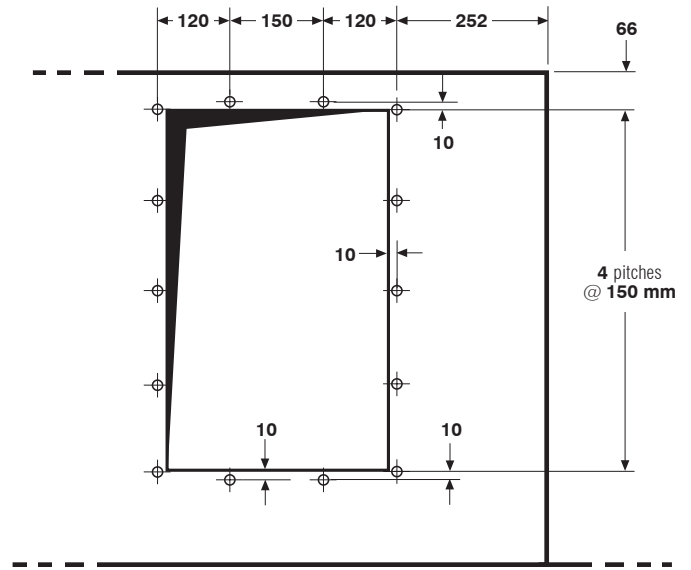

C40, C50, C60, C75 and C90
with K10 or K11 type fans

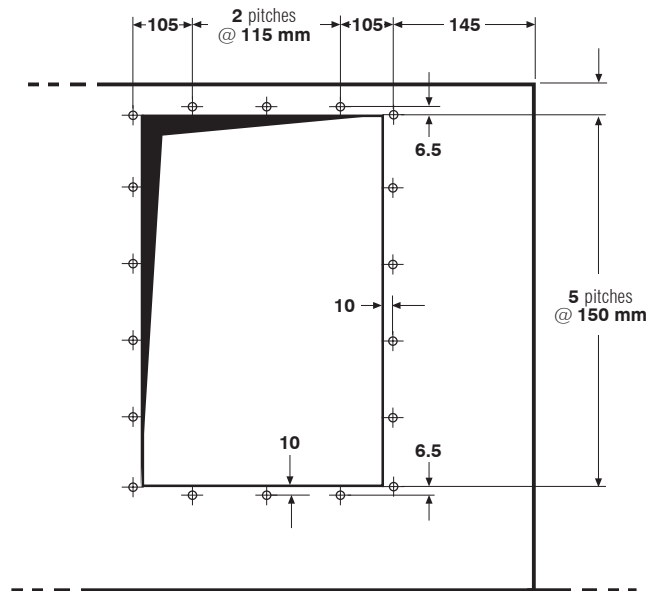

C40, C50, C60, C75 and C90 with K15, K18 or K21 type fans

**CLEANED AIR OUTLET DETAILS FOR STANDARD AND HOPPER TYPE COLLECTORS
(with outlet grille removed)**

All holes threaded for M6 set screws

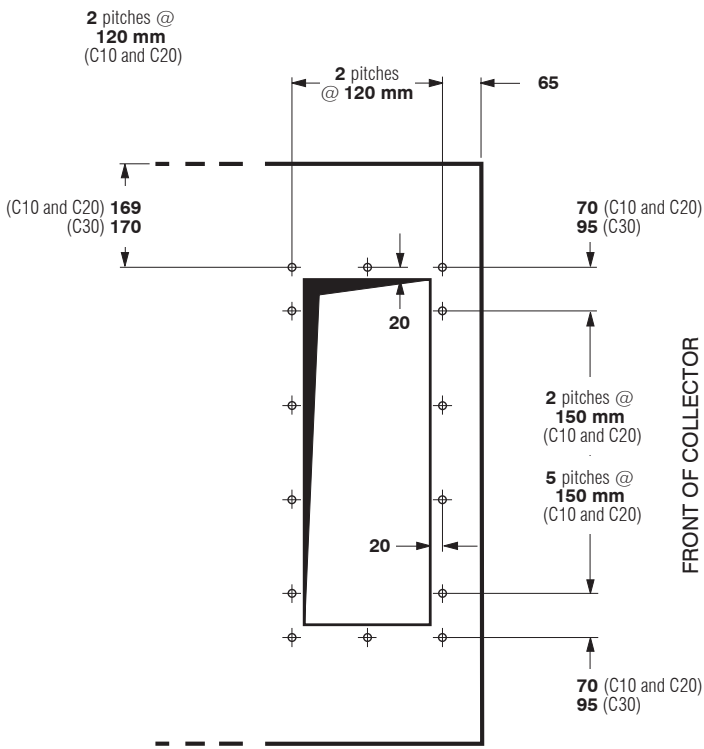

TOP VIEW

C10, C20 and C30
(C10 and C20 illustrated)
All holes Ø10mm for M8 set screws

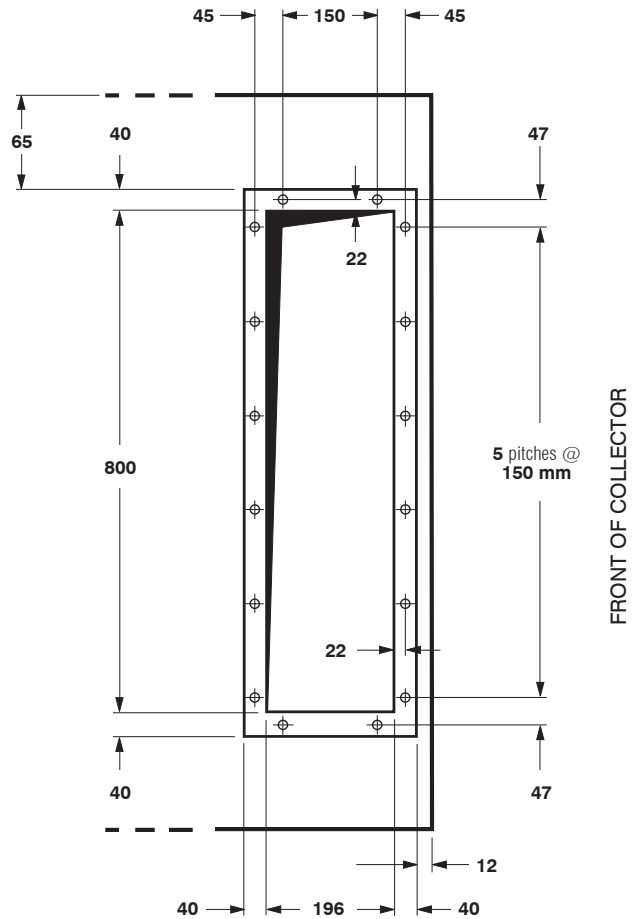

TOP VIEW

C40, C50, C60, C75 and C90
Flange projects 48mm above top of collector
All holes Ø12mm for M10 set screws

CLEANED AIR OUTLET DETAILS FOR VENTING TYPE COLLECTORS

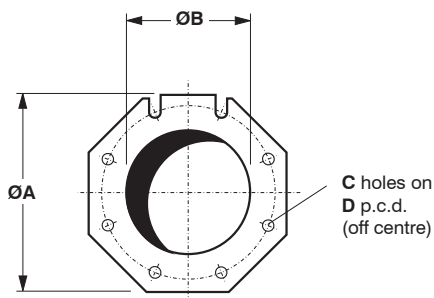

Type	A	B	C	D
C10, C20 and C30	307 mm	250 mm	8	292 mm
C40, C50 and C60	414 mm	355 mm	8	405 mm
C75 and C90	521 mm	450 mm	12	497 mm

p.c.d. to DIN 24154/2

CONTAMINATED AIR INLET DETAILS

(C10-60 illustrated)
All holes Ø12mm for M10 bolts

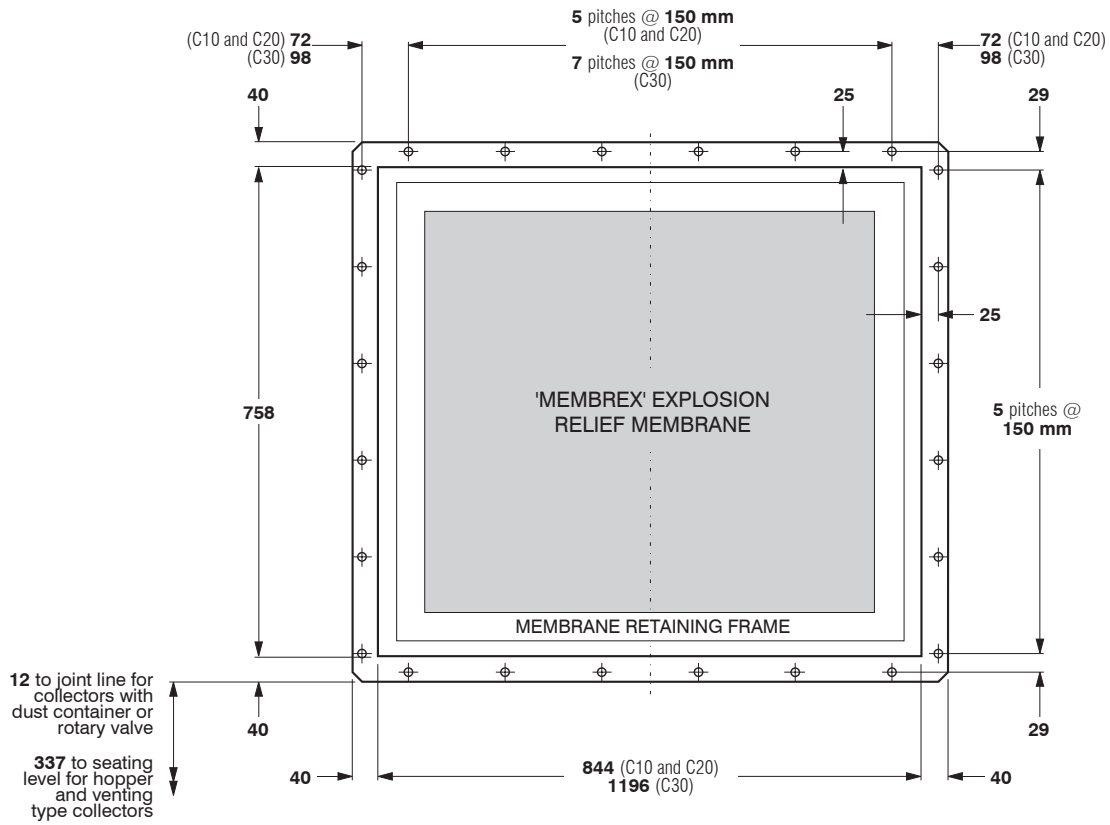

C10, C20 and C30
(C10 and C20 illustrated)
Mounting flange projects 60mm beyond rear of collector
All holes Ø10mm for M8 set screws

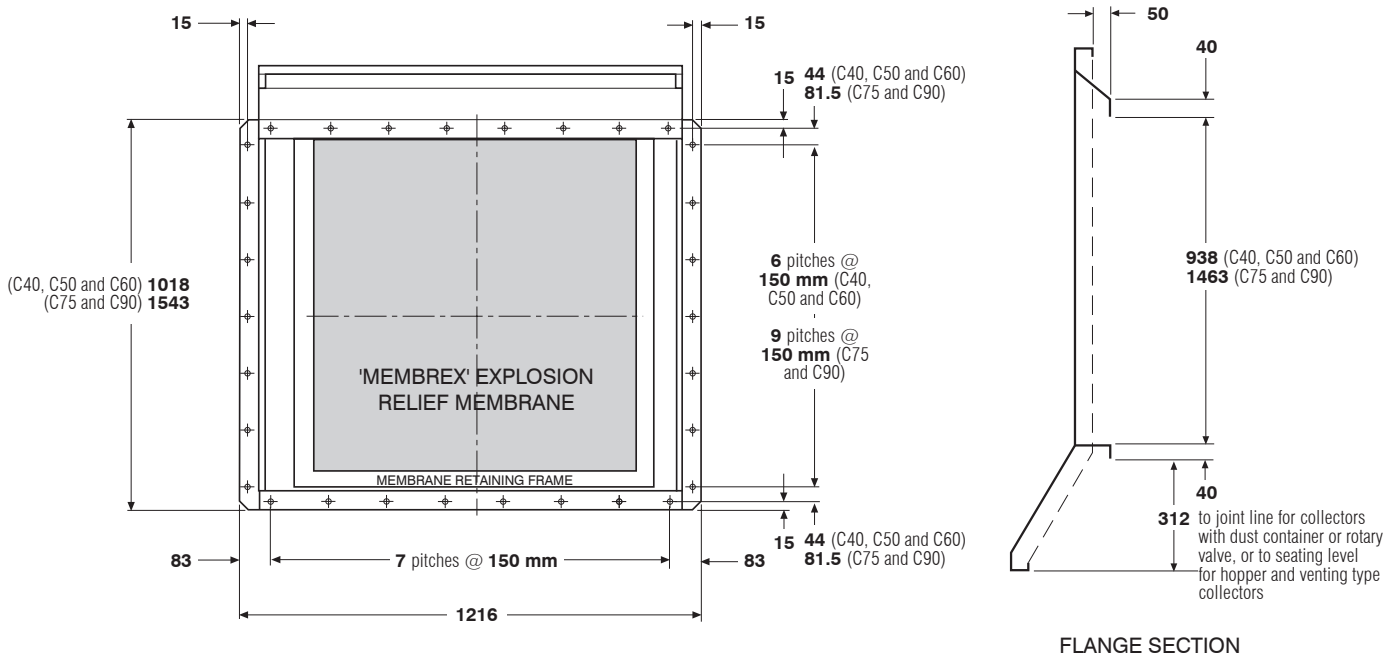

C40, C50, C60, C75 and C90
(C40, C50 and C60 illustrated)
All holes Ø12mm for M10 set screws

REAR EXPLOSION RELIEF FLANGE MOUNTING DETAILS

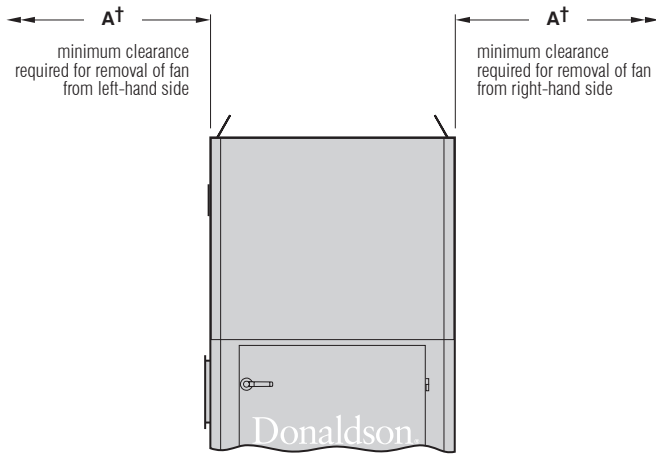

FRONT ELEVATION

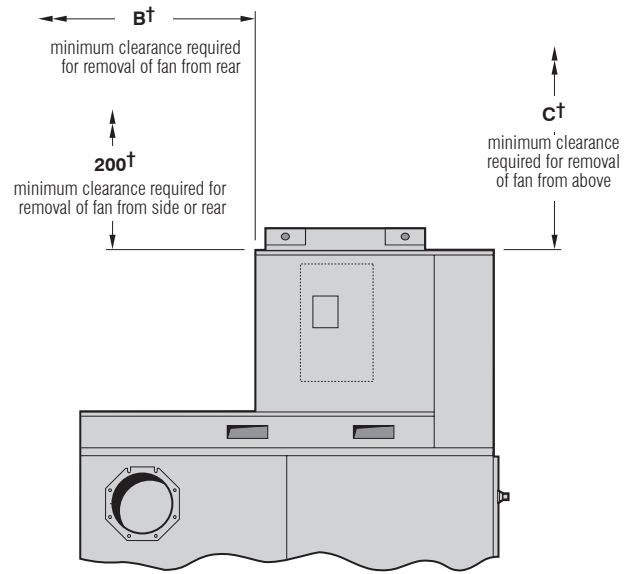

SIDE ELEVATION

UNICELL FAN REMOVAL DETAILS
(C50 K10 illustrated)

Fan assembly type	K3	K5	K7	G8	K10	K11	K15	K18	K21
Dimension A[†]	390 mm	590 mm	565 mm	690 mm	595 mm	720 mm	910 mm	930 mm	930 mm
Dimension B[†]	590 mm	590 mm	640 mm	655 mm	695 mm	725 mm	965 mm	1015 mm	1015 mm
Dimension C[†]	700 mm	700 mm	700 mm	605 mm	780 mm	830 mm	1005 mm	1025 mm	1025 mm
Weight:	55 kg	70 kg	95 kg	110 kg	125 kg	185 kg	240 kg	265 kg	370 kg

[†] Measurements are for removal of fan assembly only and do not include clearances required for lifting equipment
All weights shown indicate heaviest configuration